



ACO StormSed Vortex

Hydrodynamic Separator

DATA SHEET

The ACO StormSed Vortex is an advanced hydrodynamic separator that removes sediment bound contaminants. Its design enables removal of pollutants by means of settlement and the capture of floatables.

The ACO StormSed Vortex is available in a range of sizes to accommodate small to large sites and can be custom made for demanding installations.

The ACO StormSed Vortex retains solid pollution and oil. It also forms part of the SuDS management train as it removes over 50% of fine Total Suspended Solids as well as sediment bound metals and hydrocarbons.

Benefits

- Forms part of the SuDS management train
- Accommodates high peak flow rates with protection against remobilisation of captured suspended solids
- Delivered fitted in a plastic chamber for ease of installation
- Easy remote maintenance
- Small footprint

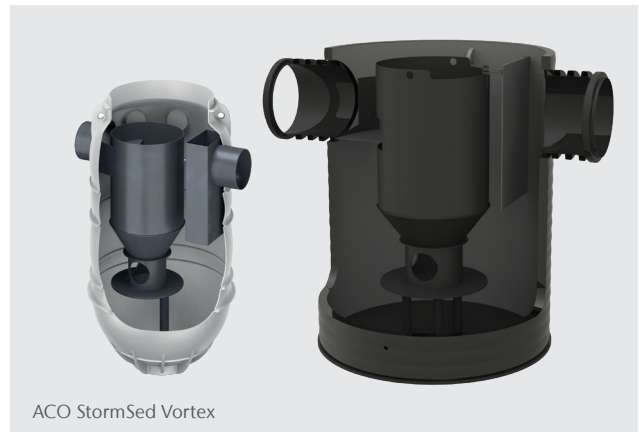

ACO StormSed Vortex

SuDS Mitigation Indices

Total Suspended Solids	Metals	Hydrocarbons
0.5	0.4	0.5

System Overview

Product name	Product code	Chamber diameter (ID)	Pipe connections (ID)	Typical treatment flow rate - 50% TSS removal efficiency	Minimum Silt/sediment storage capacity	Oil and floatables storage capacity
		mm	mm	l/s	m ³	m ³
ACO StormSed Vortex – Hydrodynamic Separator						
StormSed Vortex 750	411351	1225	DN315 (297)	12	0.225	0.300
StormSed Vortex 1000	411352	1225	375	21	0.225	0.620
StormSed Vortex 1200	40511	1200	450	30	0.598	0.569
StormSed Vortex 1500	40512	1500	500	47	0.815	0.979
StormSed Vortex 1800	40513	1800	600	68	1.723	1.945
StormSed Vortex 2000	40514	2100	750	94	1.548	3.179
StormSed Vortex 2500	40515	2400	900	123	2.013	4.300
StormSed Vortex 3000	40516	3000	900	190	3.146	7.848

How it works

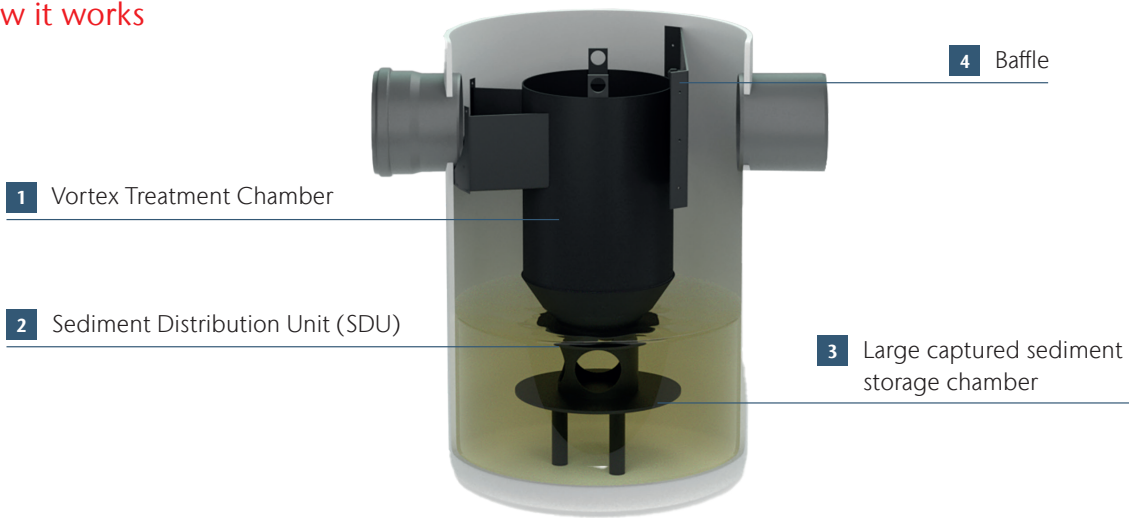

Treatment process

The design of the **ACO StormSed Vortex** creates a vortex effect in the central treatment chamber which allows effective capture of pollutants.

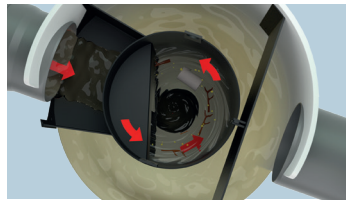

Stormwater carrying litter, suspended solids, and oils and floatables flows into the treatment chamber where the settlement of those pollutants is achieved.



During high flows when the overflow is active, the outlet baffle plate ensures all floatables are still captured.

The unique SDU design distributes the flow evenly across the device and prevents captured sediment from being flushed out.

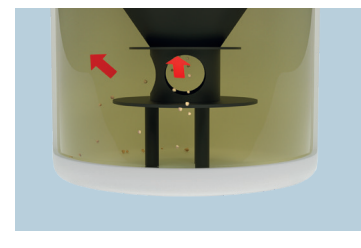

ACO Water Management Contacts:

Sales: customersupport@aco.co.uk

Technical: technical@aco.co.uk

Tel: 01462 816666

www.aco.co.uk

ACO. we care for water

