

ACO Qmax 700 FEMALE END CHAMBER CONNECTOR

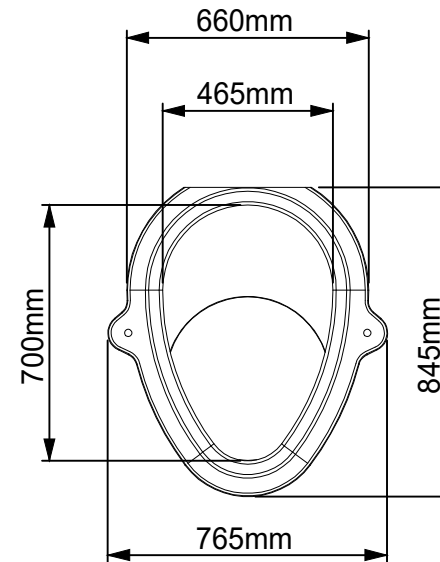

ACO Qmax 700 MALE END CHAMBER CONNECTOR

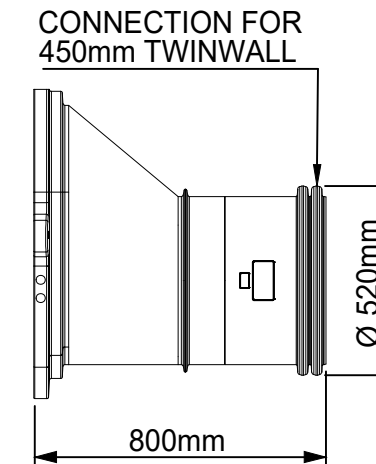

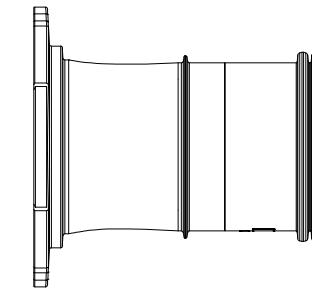
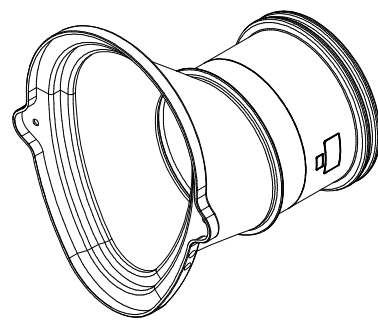

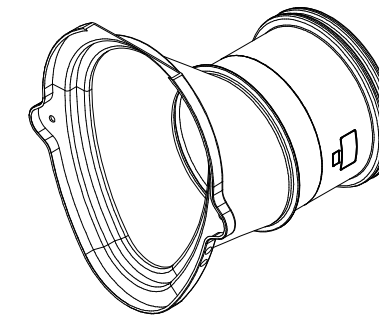
ISOMETRIC VIEW
FEMALE END CHAMBER CONNECTOR



ISOMETRIC VIEW
MALE END CHAMBER CONNECTOR

- NOTES:
- DIMENSIONS ARE FOR INDICATION ONLY AND MAY VARY DUE TO PART MANUFACTURING TOLERANCES AND INSTALLATION DETAILS
 - * CLEAR OPENING

Version	Date	Description	Name
 ACO Technologies plc	ACO Business Park Hitchin Road Shefford Bedfordshire SG17 5TE, UK Tel: 01462 816666 www.aco.co.uk	Drawing Number: E1-M01-206-1	Part Number: 32836
		Title: QMAX 700 CHAMBER CONNECTOR ASSEMBLY (PAIR)	
Created by: DEN	Released by: DEN	Projection: ISO-A 	Units: mm
Created at: 13.10.2015	Released at: 14.10.2015		Protection note: DIN ISO 16016
Replacement for:	Replaced by:	Information contained in this drawing is copyright property of ACO Technologies plc. Any reproduction in part or whole without written permission of ACO Technologies plc is prohibited	
			Scale: 1:20 Sheet: 1 of 1